

Calvary News

MONTHLY NEWSLETTER OF CALVARY LUTHERAN CHURCH OF BEMIDJI | JANUARY 2020

2508 Washington Ave SE | Bemidji, MN | 218-751-1893 | calvarybemidji.org

Winter Office Hours: Monday-Thursday - 8:30 am-4:30 pm, Friday - 8:30 am-1:00 pm, Saturday - Closed, Sunday - 8:00-11:00 am

May 2020 Be a Time of Clearer Vision for us to See God at Work

The 2020 Place was the store my dad worked as an optician when I was a child. It was on the corner of the square downtown in Fairfield, Iowa. My Dad's warm, welcoming personality had people in and out of that place regularly. Some needed new glasses, others a little adjustment, and many just needed a good story & cup of coffee. Clear vision is important to see the world, to do the work we are called to do as people of God. In this new year, 2020, we are eager to have clear vision in Christ. We will strive to see the world through God's lens. We will practice seeing one another as Christ sees us. Having God sightings in the world and in one another will help unite us as God's church. Our 2020 theme, Be Thou My Vision, is inspired by the great hymn of faith. "Be thou my vision, O Lord of my heart; naught be all else to me, save that thou are; thou my best thought both by day and by night. Waking or sleeping, thy presence, my light!"

We will experience this theme through some property improvements at Calvary, three mission trips, a new church directory, deepening partnerships in our community, and taking a look at our practices of stewardship. And I am sure God will surprise us with even more opportunities than we can plan for to keep our vision focused on what God is up to in our lives, in our families, and in our church. As we celebrate being the diverse body of Christ, we strive for unity in God's kingdom here and everywhere.

- Pastor Genelle

B
E
T
H
O
U
M
Y
V
I
S
I
O
N
O
L
J
O
E
R
S
D
U
O
S
F
M
Y
H
E
A
R
T

Calvary Lutheran Theme, 2020



TABLE OF CONTENTS

Strengthening Families	2
Annual Meeting.....	2
Undecorating Calvary	2
Search for Christmas Trees ...	2
Calvary Men's Breakfast	2
Birthdays.....	3
Christmas Concert Thanks!	3
Calvary Crafters.....	3
Happenings	3
Calendar	4
Second Offering Partner	5
Food Shelf Annual Meeting	5
Thanks for Donating	5
Evolution of Faith.....	5
Calvary Alive	5
Confirmation Fun Night.....	5
Calvary Alive Meals	5
Women's Bible Study.....	5
Financial Report	5
Thanks to Our Calvary Family	6
Lent Mentoring.....	6
Foundation Dinner	6
Stewardship Is	6

February newsletter deadline:
8 am, January 21, 2019

Please e-mail submissions to
communications@calvarybemidji.org
May be edited as space requires.

Visit our website at calvarybemidji.org to see what else is happening!

Gathering • Connecting • Serving



Strengthening Families, 2020

We are excited to again offer a Strengthening Families session for 5th graders and their parents throughout Lent. Starting Wednesday, February 26 and lasting through Wednesday, April 8, this group will meet from 6:00-8:00 pm.

Strengthening Families is a 7-week course for youth ages 10-14 and their parent/guardian(s). During these seven two-hour lessons, youth will learn how to set goals, resist peer pressure, and many other valuable skills. Parent/guardians will learn how to love with limits, learn how to communicate with their child, and much more. Brochures and registration materials will be available soon.

Please contact Kim Warren (kwarren@calvarybemidji.org) in the church office with questions or for more information.



Foundation Dinner

YOU are cordially invited to the first ever Calvary Foundation Dinner at Calvary Lutheran Church!

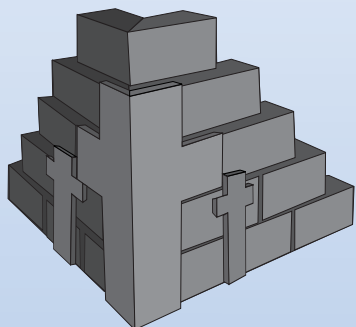

On Sunday, January 19, 2020 at 5:30 pm a free dinner and short program will be shared to celebrate the foundation and the work we do to celebrate God at work in our lives. If interested, please RSVP to the church office. We only have room for 50 people, so please check your calendars and get your name on our RSVP list!

Calvary's Annual Meeting

JANUARY 26 AT 9:30 AM

You are invited to be a part of our church family's annual meeting on Sunday, January 26 in the fellowship hall. Make sure you practice our Bible memory verse from Colossians 3:16-17. There may be prizes for those who can recite it! We will also be celebrating our year of gratitude & a successful sustainability project. We will look at the 2020 theme of Be Thou My Vision and our mission budget that will guide our ministry. Nominations for a variety of positions will be approved (we are still looking for Synod Assembly delegates for Friday, June 12 - Saturday, June 13 in Moorhead, MN. If interested, let Pastor Genelle know!). Calvary's leadership has been collecting grateful dollars each month at our meetings as we have memorized the Bible verse and shared what we are grateful for. One recurring gratitude was being a part of this church family!

Undecorating Calvary

Church undecorating will be on Sunday, January 12 after the 10:00 service. Please help undecorate and repack our beautiful decorations for another year. We will share a meal around noon. Many hands make light work!



Calvary's Men's Breakfast

All men are welcome and invited to join us for our Men's Breakfast and bible study each Wednesday at Perkins Restaurant. This group meets at 6:30 am for faith and fellowship. We will resume our 2020 meetings on January 8. Contact Pr. Jeremiah in the office for more information.



Birthdays This Month

Please pray in celebration for these people on their birthday. If your birthday is not listed, or is not correct, please call the church office to update our records.

- 01-Jan Mark Jensen, Wade Weik, Harper Kingery
02-Jan Jeff Aas, Michael Summers
03-Jan Susan Eichstadt, Tyler Moran
04-Jan Ashley Johnson, Alex Hasbargen, Andrew Nelson, Aubrey Nelson, Cole Evje, Isaiah Turney
05-Jan Randy Frisk, Melissa Rickers, Leslie Bartels, Heather Bjorgaard, Michael Strodtman, Steve Molde, Christian Fettig, Jereko Senenfelder
06-Jan Desiree Quinn, Grant Mueller, David Forsberg
07-Jan Marv Lawyer, Jay Passa, Sharon Hoverson, Jeffrey Wilcox, Amy Riley, McKayla Beaulieu, Erin Blake, Kinley Prestegard, Peyton Rognstad, Marshall Farr
08-Jan Sylvia Olney, Bambi Kuyper
09-Jan Mary Settle, Kris Sorenson, Sonia Wadena, Hunter Bahl
10-Jan Brenden Sherwood
11-Jan Dale Peterson
12-Jan Terry Matson, Tanya Clemenson, Haley Brodina, Allison Riley
13-Jan Arlyce Sipe, Claire Wick
14-Jan Loren Hoyum, Thomas Quinn, Brynn Thorson
15-Jan Samuel Hodgson, Blake Stenseth
16-Jan Grant Coauette, Tiffany Dunn, Ian Hamann, Carson Katke
17-Jan Gayle Quistgard, Nate Andersen
18-Jan Harlan Olson, Lucas Goins, Darian Smith
19-Jan Kerry Frauenholtz, Sam Holm, Jack Luebben, Olivia Rohde
20-Jan Sharon Molde, Logan Roubal
21-Jan Robin Suther, Scott Rogers, Zachary Folkert, Lawren Wadena, Chloe Hasbargen
22-Jan Zelda Larson, Dan Luby, Dave Port, Josh Zellmann, Noah Bitz, Hayden Pirkel, Oscar Larson
23-Jan Ron Anderson, Doug Flatness, Trevor Trepanier, Ben Hodgson, Allison Howard, Cooper Kuzel
24-Jan Britta Aas
25-Jan Janna Schiltz, Harrison Minske, Kanan Skoog, Hannah Nettetstad
26-Jan Norma Frisk, Caroline Kinnen
27-Jan Laureen Lawyer, Ken Schreiber, Mark Stokes, Tom Hatfield, Harli Jackson, Garrett Folkert, Emma Erickson
28-Jan Monte Fjosne, John Strowbridge, Will Falldorf, Leonard Sellheim
29-Jan Gail Edman, Andrea Brodina, Ethan Halvorson
30-Jan Kevin Barsch, Trevor Loewe
31-Jan Alice Lindgren, Ron Tuck, Coralyn Strodtman, Elena Harmsen

What a Fun & Successful Christmas Concert!

Thank you to all the performers, attendees, and volunteers that helped with our 3rd Annual Christmas Concert! We had a wonderful turnout, a great time, and raised over \$700!

Yea God!

Calvary Crafters, 2020

Calvary Crafters will not be meeting over the winter. Meetings will resume in May, 2020. Thank you to everyone who knitted, crocheted, and otherwise created items for us in 2019. Your help, knowledge, and dedication was a blessing to all those involved throughout the year.

HAPPENINGS

MEN'S BREAKFAST & BIBLE STUDY
Perkins Restaurant, Weds., 6:30 am

GATHER BIBLE STUDY
Every other Thurs. at 11:00 am - Room 1
Contact Vicar Daphne (751-1893)
Materials will be provided to you!

MARTHA CIRCLE BIBLE STUDY at
Calvary, 3rd Tues. each month, 1:30 pm

HOPE CIRCLE BIBLE STUDY at
Calvary, 3rd Tues. each month, 9:30 am

MARIGOLD CIRCLE BIBLE STUDY
1st Mon. each month, 10:00 am. Contact
Linda Arnold (759-9702)

JOHN EGGERS' BIBLE STUDY
Weekly on our website or via Enews.

ZUMBA CLASS at Calvary, 11:00 am
most Sundays. sarahbendorf.zumba.com
Find her on Facebook w/ [Sarah B Zumba](https://www.facebook.com/SarahBZumba)

QUILTERS at Calvary, 9:00 am - Room 4,
in the quilting room most Thursdays.

CRAFTERS at Calvary, 7:00 pm the 2nd
and 4th Monday of every month. Contact
Cheryl with any questions - 368-3098

JANUARY 2020

Sunday	Monday	Tuesday	Wednesday	Thursday	Friday	Saturday
<p>29 8:30 AM Worship - Lessons and Carols 9:00 AM - 11:00 AM Coffee Fellowship 10:00 AM Worship - Lessons and Carols 5:30 PM - 8:30 PM Northwind Martial Arts</p>	<p>30 No Preschool or Childcare Painting Projects: Library, coat hallway, room #7, family bathroom</p>	<p>31  No Preschool or Childcare Painting Projects: Library, coat hallway, room #7, family bathroom 12:00 PM Calvary Office Closed 7:00 PM Narcotics Anonymous</p>	<p>1 New Year's Day No Preschool or Childcare Office Closed Painting Projects: Library, coat hallway, room #7, family bathroom 6:15 PM No Calvary Alive Worship 8:00 PM AA - Pine Tree Mtg</p>	<p>2 No Preschool or Childcare Ministry Team 9:00 AM - 12:00 PM Quilling 11:00 AM - 1:30 PM "Gather" Bible Study with Vicar Daphne 4:30 PM - 6:30 PM Just for Kix</p>	<p>3 No Preschool or Childcare 11:00 AM - 1:30 PM Friday Men's Basketball 8:00 PM AA - Pine Tree Mtg</p>	<p>4 2:00 PM - 4:00 PM Birthday Party 4:00 PM - 5:00 PM Boy Scouts Pizza Party 6:00 PM Praise Team Rehearsal</p>
<p>5 8:30 AM Worship 9:00 AM - 11:00 AM Coffee Fellowship 9:00 AM Sunday School for PK-grade 2 9:30 AM Adult Ed: Evolution of Faith - Simon Peter - with Pr. Jeremiah 10:00 AM Worship 10:30 AM Sunday School for PK - grade 2 11:30 AM Zumba with Sarah</p>	<p>6 10:00 AM Merigold Circle (in members homes) 4:30 PM - 8:30 PM Just for Kix 7:00 PM - 8:00 PM Boy Scout Troop 82</p>	<p>7 9:15 AM - 3:30 PM Northwoods Homeschool Classes 9:30 AM - 12:00 PM Pastors Conference Lunch and Program 9:45 AM - 10:00 AM Preschool Chapel 4:30 PM - 8:30 PM Just for Kix 7:00 PM Narcotics Anonymous</p>	<p>8 6:30 AM Men's Breakfast & Bible Study - Now at Perkins 9:45 AM - 10:00 AM Preschool Chapel 10:00 AM Wednesday Bible Study 3:00 PM - 5:00 PM Kingdom Kids Winter 5:30 PM - 6:10 PM Calvary Alive Meal 6:15 PM Calvary Alive Contemporary Worship 7:15 PM Choir Rehearsal 7:15 PM Confirmation 7:15 PM Youth Club 8:00 PM AA - Pine Tree Mtg 8:00 PM Kingdom Kids Family Planning Meeting</p>	<p>9 9:00 AM - 12:00 PM Quilling Ministry Team 9:15 AM - 3:30 PM Northwoods Homeschool Classes 4:30 PM - 8:30 PM Just for Kix 6:00 PM - 8:45 PM Boy Scouts Round Table 6:00 PM Praise Team Rehearsal</p>	<p>10 9:00 AM - 12:30 PM Bi-Cap Staff Training 11:00 AM - 1:30 PM Friday Men's Basketball 8:00 PM AA - Pine Tree Mtg</p>	<p>11 8:30 AM - 9:15 AM Kangoo Jumps Exercise Class with Leah Hendricks</p>
<p>12 Baptismal Festival 8:30 AM Worship 9:00 AM - 11:00 AM Coffee Fellowship support Jamaica Mission Trip 9:00 AM Sunday School for PK-grade 2 10:00 AM Worship 10:30 AM Sunday School for PK - grade 2 11:30 AM Zumba with Sarah 6:00 PM Jamaica Mission Trip Meeting</p>	<p>13 4:30 PM - 8:30 PM Just for Kix 6:00 PM - 7:00 PM Boy Scout Troop 80 7:00 PM - 8:00 PM Boy Scout Troop 82</p>	<p>14 Preschool Staff Meeting 9:00 AM - 10:30 AM MTL Staff Meeting 9:15 AM - 3:30 PM Northwoods Homeschool Classes 4:30 PM - 8:30 PM Just for Kix 7:00 PM Narcotics Anonymous</p>	<p>15 6:30 AM Men's Breakfast & Bible Study - Now at Perkins 10:00 AM Wednesday Bible Study 3:00 PM - 5:00 PM Kingdom Kids Winter 4:30 PM - 6:00 PM Calvary Council (3rd Wednesday) 5:30 PM No Calvary Alive Meal 6:00 PM - 8:00 PM Confirmation Fun Night at Buena Vista 6:15 PM Calvary Alive Contemporary Worship 7:15 PM Choir Rehearsal 7:15 PM Youth Club 8:00 PM AA - Pine Tree Mtg</p>	<p>16 9:00 AM - 12:00 PM Quilling Ministry Team 9:15 AM - 3:30 PM Northwoods Homeschool Classes 4:30 PM - 8:30 PM Just for Kix 6:00 PM Praise Team Rehearsal</p>	<p>17 11:00 AM - 1:30 PM Friday Men's Basketball 12:00 PM Decade Group - Lunch at Giovanni's 8:00 PM AA - Pine Tree Mtg</p>	<p>18 8:30 AM - 9:15 AM Kangoo Jumps Exercise Class with Leah Hendricks</p>
<p>19  8:30 AM Worship 9:00 AM - 11:00 AM Coffee Fellowship 10:00 AM Worship 11:30 AM Zumba with Sarah 2:00 PM - 4:30 PM Sons of Norway Meeting 5:30 PM - 6:30 PM Calvary Foundation Dinner</p>	<p>20 Martin L. King, Jr. Day No Preschool/Yes Childcare 4:00 PM - 9:00 PM Quilling in Room 7 4:30 PM - 8:30 PM Just for Kix 7:00 PM - 8:00 PM Boy Scout Troop 82</p>	<p>21 Newsletter Deadline 9:00 AM - 10:30 AM MTL Staff Meeting 9:15 AM - 3:30 PM Northwoods Homeschool Classes 9:30 AM - 11:30 AM Hope Circle 1:30 PM Wertha Circle 4:30 PM - 8:30 PM Just for Kix 7:00 PM Narcotics Anonymous</p>	<p>22 6:30 AM Men's Breakfast & Bible Study - Now at Perkins 10:00 AM Wednesday Bible Study 3:00 PM - 5:00 PM Kingdom Kids Winter 5:30 PM - 6:10 PM Calvary Alive Meal 6:15 PM Calvary Alive Contemporary Worship 7:15 PM Choir Rehearsal 7:15 PM Confirmation 7:15 PM Youth Club 8:00 PM AA - Pine Tree Mtg</p>	<p>23 9:00 AM - 12:00 PM Quilling Ministry Team 9:15 AM - 3:30 PM Northwoods Homeschool Classes 4:30 PM - 8:30 PM Just for Kix 6:00 PM Praise Team Rehearsal</p>	<p>24 8:30 AM - 4:30 PM Early Childhood Training with Metro ECSU 11:00 AM - 1:30 PM Friday Men's Basketball 5:30 PM - 7:00 PM Preschool Pancakes and PJ Family Night 8:00 PM AA - Pine Tree Mtg</p>	<p>25 7:00 AM Calvary Women's Coffee Break 8:30 AM - 9:15 AM Kangoo Jumps Exercise Class with Leah Hendricks</p>
<p>26 Calvary Annual Meeting 8:30 AM Worship 9:00 AM - 11:00 AM Coffee Fellowship 9:00 AM Sunday School for PK-grade 2 10:00 AM Worship 10:30 AM Sunday School for PK - grade 2 11:30 AM Zumba with Sarah</p>	<p>27 4:30 PM - 8:30 PM Just for Kix 6:00 PM - 7:00 PM Boy Scout Troop 80 7:00 PM - 8:00 PM Boy Scout Troop 82</p>	<p>28 Meeting 9:15 AM - 3:30 PM Northwoods Homeschool Classes 4:30 PM - 8:30 PM Just for Kix 7:00 PM Narcotics Anonymous</p>	<p>29 6:30 AM Men's Breakfast & Bible Study - Now at Perkins 10:00 AM Wednesday Bible Study 3:00 PM - 5:00 PM Kingdom Kids Winter 5:30 PM - 6:10 PM Calvary Alive Meal 6:15 PM Calvary Alive Contemporary Worship 7:15 PM Choir Rehearsal 7:15 PM Confirmation 7:15 PM Youth Club 8:00 PM AA - Pine Tree Mtg</p>	<p>30 9:00 AM - 12:00 PM Quilling Ministry Team 9:15 AM - 3:30 PM Northwoods Homeschool Classes 11:00 AM - 12:30 PM "Gather" Bible Study with Vicar Daphne 4:30 PM - 6:30 PM Just for Kix 6:00 PM Praise Team Rehearsal</p>	<p>31 11:00 AM - 1:30 PM Friday Men's Basketball 8:00 PM AA - Pine Tree Mtg</p>	<p>1</p>

PLEASE CHECK OUR WEBSITE FOR THE MOST UP-TO-DATE CALENDAR : If you are aware of an event that should go in the Calvary calendar, please contact Polly at pmerhar@calvaryhemijiji.org by the newsletter deadline.

2ND OFFERING MINISTRY PARTNER - CHURCHES UNITED

All of us have both spiritual and physical needs. Churches United is one place where God is working to provide especially for the physical needs of our neighbors. Located in the old Lincoln School on 4th Street in Nymore, and open Monday, Tuesday, Thursday, and Friday from 12-4:00 pm, Churches United is a place where people can go to receive material and financial assistance in the name of Jesus. Around twenty area churches work together through this ministry to provide gas and food vouchers, bus and laundry tokens, and other gifts for community members in need. This is vital work! Thanks for your support.



Remember: Our partnerships are about more than just money. Churches United is in need of volunteers who will come in on a regular basis to help out in a way that works for the volunteer: file papers, enter information in the computer, or provide hospitality to guests. Call 444-1380 and talk to Wanda to help out.

For God's Treasure Chest this month, we are looking for personal care items and men's gloves. *While we will take a second offering each month (January 8 & 12), you are encouraged to give throughout the month to our ministry partners. We ask that ALL checks be made out to Calvary Lutheran. In the memo line, write our mission partner for the month. This will help with better record keeping.*

Evolution of Faith - Simon Peter

ADULT EDUCATION WITH PR. JEREMIAH

On Sunday, January 5th, Pr. Jeremiah will be hosting an education hour focusing on Simon Peter and the evolution of his faith throughout the Gospel story. This event will begin at 9:30 am in Calvary's Room 9. Come and discuss this hero of our faith, and how he came to better understand the mission of God in the world.

Save the Date: Food Shelf Annual Meeting

AT BETHEL LUTHERAN CHURCH ON FEBRUARY 13 AT 12:00 PM

Please mark your calendar for our annual meeting Thursday, February 13 at noon in the Fellowship Hall of Bethel Lutheran Church. We will be serving a light lunch featuring homemade soups and desserts. The program will consist of volunteer recognition and a celebration of our work during 2019. Come celebrate with us!

Confirmation Fun Night at Buena Vista

Our youth will be visiting Buena Vista for some tubing fun on Wednesday, January 15. For this reason, we will not be serving a Calvary Alive meal in the evening. We will, however, still have our usual programming that night, as well as a worship service at 6:15 pm. Join us for some great fellowship!

Community Women's Bible Study

**DANIEL – LIVES OF INTEGRITY, WORDS OF PROPHECY
BY BETH MOORE**

This 12-week session deals with Daniel's life as he faced the pressures and temptations that Christians encounter today and how he modeled integrity in an enticing world. We will also explore thrilling prophecies from the time of Daniel through the second coming of Christ. This group will meet at 6:30 pm Monday evenings, beginning January 13, 2020 at Evangelical Free Church of Bemidji. The cost of a book for this group is \$20.00.

Please email jritchie@paulbunyan.net or call the E Free church office at 218-751-8834 by January 5th to reserve a book.

Thank You for Donating to Our Angel and Hat, Scarf, & Mitten Trees!

We would like to thank everyone that selflessly donated to our Hat, Scarf, & Mitten Tree, as well as those who donated Angel Tree gifts. Every year there are families that struggle to provide gifts or basic clothing for warmth to their children. Your generosity helps the less fortunate have a little more cheer in their families' holiday season!

Thank you for helping spread the Christmas spirit!

January Calvary Alive Meals:

1st - No Worship or Meal
8th - Watch for Our Meal on Facebook
15th - No Meal - Buena Vista Tubing Day
22nd - Watch for Our Meal on Facebook
29th - Watch for Our Meal on Facebook

If you would like to volunteer for this great ministry, or even help cook, please contact Karin Harrison! You can obtain more information or sign up to help in the office, or by emailing kharrison@calvarybemidji.org.

FINANCIAL REPORT

November	Income	Expenses
General Fund	\$66,412.....	\$54,503
Y-T-D	\$738,715.....	\$741,328
Preschool ...	\$25,095.....	\$32,732
Y-T-D	\$151,770.....	\$127,800

Gen. Fund is Jan.-Dec.; Preschool is July-June

Cash & Receivables \$110,690

November Ministry Partner:

Lutheran World Relief:..... \$1,620

Calvary Foundation Balance: \$38,476



A Thank You for Our Calvary Family!

Thank you to everyone that helped with our Christmas Concert, bell ringing, programs, community meals, worship, Lutefisk, Calvary Alive, our many events, mission trips, or anything else Calvary in December, or throughout 2019. Whether you put your faith into action with us outside of Calvary, visited our homebound members, helped us within Calvary's walls, or just showed up to worship along your brothers and sisters, we are extremely grateful for our Calvary family and the support that you provide us.

Thank You

From all of us here at Calvary, thank you all so much for such a great year! Here's to another great upcoming year!!

Confirmation Lent Mentoring

We are looking for adults, (especially men,) to serve as mentors for our confirmation students on Wednesday nights for the season of Lent. Starting on Wednesday, February 26 through April 8, we will gather for worship at 6:15 PM where we will watch a video as a congregation and then we will have about 15 - 20 minutes of one on one time discussing the video (discussion questions are provided.) If interested or if you have any questions, please contact Kim Warren (kwarren@calvarybemidji.org) in the church office.



Calvary is in Search of Christmas Trees

Downsizing or buying a new tree for your home? Calvary is looking to replace a few of the Christmas trees that we use for decorating our church. If you have one that is in good shape, and are looking to find a new home for it, please contact Polly or Shar before we purchase new ones.

Thank you, and God Bless!

Thanks for Your Help With Our Annual Project!

We would like to give a special thank you to all those who helped us successfully complete our annual project for 2019. We had a multitude of volunteers help with the coordination, installation, and support throughout the days of our LED retrofit. We also had tons of people support this cause through donations to Calvary to go toward our LED project.

Our halls, classrooms, and offices are now filled with a more natural light that make things brighter and help us feel more energized throughout the day. On top of that, Calvary has already witnessed several thousands of dollars from energy savings through the end of 2019 due to this wonderful change! Thank you again to everyone for making this incredible change possible and supporting us every step of the way. You are all truly generous people of God!

Stewardship Is...

Stewardship is a word we use in the church to think about how we are managing our lives, our time, and our treasurers. Calvary has a lot of responsibility given to us to steward. We have a large, well used building that gathers us for worship, fellowship, and education, (did you know we have 7 furnaces?!) We have 40 acres of land to steward, (did you know we have a prayer path with an outdoor worship space?) We have 28 staff members to care for whom we entrust to help us live out our mission goals, (did you know that we have college interns working here?) We have over a million dollars filter through this church each year, (did you know that we give around \$70,000 away, which doesn't include mission trip dollars and workers!) This year we will be taking a deeper look at stewardship - what we have been given, to be responsible for, as God's children. You will have an opportunity to take a look at your own calling to be good stewards of what God has blessed us with as well as the church taking a look too.

